

INVISIBLE FOR HOME TECHNOLOGY ARCHITECTS



HTA-26

Recommended Applications:

- Multi-Room Audio Systems
- Background Music
- Foreground Music
- Voice Paging
- Sound Masking Systems
- Home Theater / Surround Sound

Recommended Installations:

Flush mounted in walls or ceilings constructed of wood or steel framing with 13mm (1/2") or thicker gypsum wallboard. Minimum 57mm (2 1/4") cavity depth required.

Performance:

- 100 Watts RMS
- 45Hz to 20kHz (see Figure 1)
- 50W minimum recommended power

Protection:

Two independent self-resetting circuits (low and high-frequency).

On-Site Finish Options:

Finish options include latex paint, flat finish, orange peel texture, light plaster, light wallpaper, light fabric, wood veneer, and other selected approved finishes.



6.5" 2-WAY INVISIBLE IN-WALL OR IN-CEILING LOUDSPEAKER

The Home Technology Architects 6.5" 2-way, full-range loudspeaker becomes completely invisible after installation. The loudspeaker has a rigid frame that attaches directly to standard structural framing. The paintable active diaphragm face is bonded to the frame of the speaker panel, creating an active area surrounded by a stable mounting area. Installation instructions are shown on a paper overlay that is to be removed before installation. The overlay can also be used as a cutting template for retrofitting the speakers into existing wallboard.

The speaker may be installed in either the wall or ceiling and on-site finishing options include latex paint, light wallpaper, fabrics and selected texture coats. There is no need for special vellums or other nonstandard wallboard finishing materials. Advanced finishing methods may be supported using special techniques.

The invisible speaker incorporates an acoustically coupled high quality, high-power 6.5" cone woofer and a direct coupled 30 mm neo-magnet high-frequency driver. Advanced internal materials allow for smooth frequency extension to 20kHz. When installed in the recommended back box, frequency response below 45Hz can be achieved. The speaker contains two independent protection circuits (high-frequency and low-frequency sections) that automatically reset upon reduction of excessive amplifier power.

For proper registration, each speaker must be installed so that the surface of the **perimeter edge is flush** with the adjoining wallboard. When correctly in place, the surface of the speaker **face panel extends above** the height of the wallboard by 2mm (1/16"). This is done to allow space for the tape and joint

compound needed to blend the panel into the wall. Shims are included to allow for mounting in wallboard thicker than 13mm (1/2").

These invisible speakers offer a powerful advantage over traditional architectural loudspeakers because they can be placed wherever they sound best, free of visual concerns that may conflict with architectural features.

To accompany these full range speakers, completely invisible companion subwoofers are available to extended low frequency response.

These speakers are covered by a 5 year manufacturer's warranty.

HTA-26

6.5" 2-WAY INVISIBLE IN-WALL OR IN-CEILING LOUDSPEAKER

Architectural & Engineering Specifications

The loudspeaker shall be a two-way, full-range device, producing frequencies from 45Hz to 20kHz. The total radiating surface shall be 735 sq. cm (114 sq. in) and high frequency dispersion shall be a nominal 170 degrees in both horizontal and vertical planes. The loudspeaker system shall have a sensitivity of 83 dB, 1 watt / 1 meter, with a capacity of 100 watts RMS according to EIA standard RS-426-A. The loudspeaker shall have two independent self-resetting protection devices, one each for the high-frequency driver and the low-frequency driver.

The loudspeaker shall fit into walls or ceilings with standard wood or steel stud construction and a minimum 57mm (2¼") depth cavity. The loudspeaker shall mount directly to the structural framing and have the capability of seamlessly adjoining 13mm (½") or thicker gypsum wallboard. The minimum distance between framing members shall be 216mm (8½"). Face panel finishing methods shall be consistent with normal gypsum wallboard finishing techniques and may include latex paint, light wallpaper, light fabric wood veneer and other selected approved finishes.

The loudspeaker shall carry a 5 year manufacturer's warranty.

Product Specifications

Frequency Response:

45Hz to 20kHz (see Figure 1)

Power Capacity:

100 watts RMS

50 watts minimum recommended power

Protection:

Two independent self-resetting devices
(low and high frequency)

Sensitivity:

83 dB (1 watt / 1 meter)

Driver Components:

High frequency: 30mm (1⅝") neodymium driver

Low-frequency: 25mm (1") voice coil, 165mm (6.5") woofer,
425 gr (15 oz.) ceramic magnet

System Impedance:

8Ω nominal

Polar Dispersion:

170 degrees vertical and horizontal

Dimensions:

Width: 403mm (15⅞")

Height: 302mm (11⅞")

Mounting Depth: 57mm (2¼")

Product Weight:

3.9 kg (8.7 lbs.)

Shipping Weight:

8.6 kg. (19 lbs) per pair

5.4 kg (12 lbs.) per single

Included Accessories:

Mounting shims

Mounting screws

Designing Invisible Sound Systems

Invisible Sound Systems require the appropriate Backbox, Cable and Amplifier with Digital Sound Processing (DSP).

Contact us for free consultation and system design: www.genesis-hta.eu

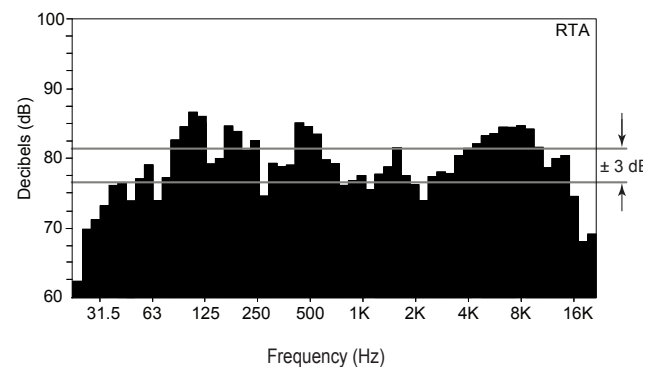
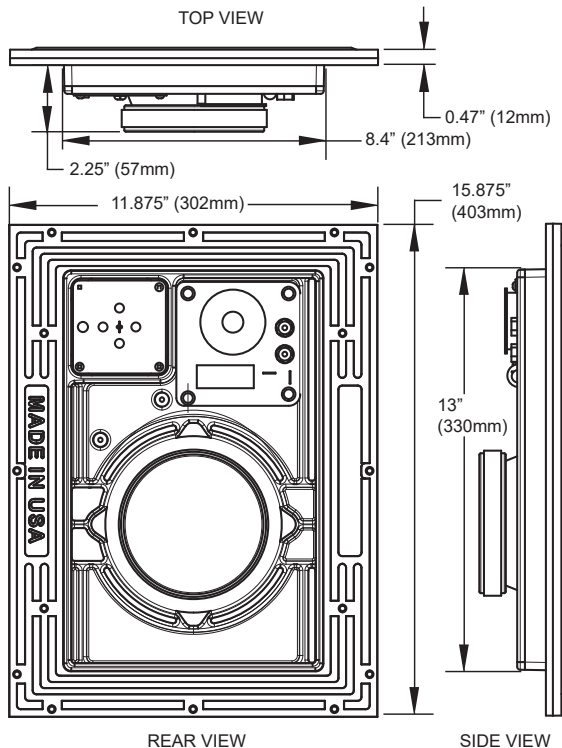

Figure 1: On-axis frequency response in standard stud wall with four coats of latex paint applied to the speaker face panel.



Sold and Installed by [Home Technology Architects](#) exclusively.

Definition: A Home Technology Architect is an engineering company with the expertise and know-how to deliver home technology solutions that are simple, reliable and beautiful.